



SHREDDER EVOLUTION

SHREDDER EVOLUTION





**TWIN SHAFT
SHREDDER**



**INTELLIGENT LOAD
MANAGEMENT**



HIGH TORQUE



**HIGH RESISTANCE TO
NON-SHREDDABLES**



VS420 SERIES FEATURES AND BENEFITS



The EDGE VS420 is a high capacity, high torque twin shaft shredder that is ideal for the processing of a large array of materials including; green waste, MSW, C&D waste, biomass and end of life tyres.

EDGE's next generation shredder has been developed for ultimate versatility and high resistance to contaminants with a number of customisable shredding programmes and chamber configurations available. An intelligent operating system which incorporates tramp metal protection provides the ultimate protection from contaminants and prevents asset damage.

At the heart of the VS420 are twin synchronised, high torque shredder shafts which can be customised to suit a customer's exact application and desired product piece size. EDGE's twin shaft design provides exceptional material intake, ensures less wear, promotes self-cleaning and prevents material wrapping even in the toughest of applications. With a range of both rapid volume reduction and intricate piece sizing chambers available, The EDGE VS420 series can be customised to be deployed as either a primary or secondary shredder





KEY HIGHLIGHTS

- Highly robust design provides high durability and the ability to withstand difficult to shred materials.
- Twin Shaft design provides exceptional intake behaviour, less wear, self cleaning and prevents material wrapping.
- Intelligent Self-Protecting control system with tramp metal cycles prevents against asset damage.
- Eco-power saving functionality coupled with a fuel consumption from as little as 25/30ltr/hr. (7-8 US Gallons)

VS420 SERIES

DESIGN FEATURES

Twin synchronised shredder shafts incorporating EDGE's Intelligent Self-Protecting control system.

Hydraulic Hopper Extensions increases hopper capacity and loading flexibility

1400mm (55") wide Discharge Conveyor provides a maximum discharge height of 4.7m (15'6")



Enables one man operation with all main functions controlled via wireless remote

Hydraulic height adjustable overband magnet with remote functionality

THE RIGHT CHAMBER FOR EVERY APPLICATION

Heavy duty, hydraulic tipping hopper with automatic tipping cycle

VS Status Link provides a quick and simple communication link between the machine and the operator



C9.3B ACERT 310Kw (420HP) Tier 4 Final / Stage 5 engine. LRC Engine option also available

User Friendly control interface provides easy fine tuning and programme selection

Hydraulically driven, remote controlled tracks for easy on site mobility

APPLICATIONS

MSW

GREEN WASTE

C&D WASTE

WOOD WASTE

RUBBER TIRES

WHITE GOODS

MATTRESSES



VS420 SERIES

TECHNICAL SPECIFICATIONS

TRANSPORT DIMENSIONS

Length:	9706mm (31'10")
Width:	2550mm (8'4")
Height:	3145mm (10'4")
Container Shipping Method:	RoRo
Gross Weight (Est):	29200KG (32.1UST)

Shredder Type	Vertical Slow Speed
Drive Type:	Hydraulic
Number of Shafts:	2
Shaft Length:	2m / 2.5m (6'7" / 8'2")
Shaft Diameter:	655mm (25.5")

HOPPER DATA

Hopper Capacity:	4.4m ³ (5.75yd ³)
Hopper Capacity w/Extensions	6.4m ³ (8.3yds ³)
Loading Height:	3145mm (10'4")
Loading Height w/ Extensions:	3583mm (11'9")
Tipping Mechanism:	Hydraulic

COLLECTION CONVEYOR DATA

Conveyor Length:	2800mm (9'2")
Belt Width:	1400mm (55")
Belt Speed	Variable

AVAILABLE OPTIONS

Tracked unit	Tier 3 LRC Engine	Dust Suppression	Fire Suppression
Wheeled Unit	Electric / Hydraulic (Static Only)	Discharge Conveyor Dust Cover	Telematics
Hook-lift Unit	Overband Magnet	Discharge Conveyor Head Chute	
Static Unit	Magnetic Head Drum & Chute	Various Screen Apertures & Shapes	
Fine Shredding Chamber	Reversible Fan	Rubber Track Pads	
Universal Shredder Chamber	Auto Lube System	Arctic Pack	
Bulky Waste Chamber	Hydraulic Hopper Extensions	Auxiliary Hydraulic Connections	

DISCHARGE CONVEYOR DATA

Conveyor Length:	6900mm (22'7")
Belt Width:	1400mm (55")
Belt Speed	Variable

POWERUNIT DATA

Power Source:	Tier 4 Final CAT C9.3B 310Kw (420HP)
Fuel Tank Capacity:	630 Litres (166USG)

VS420 SERIES TECHNICAL DIMENSIONS

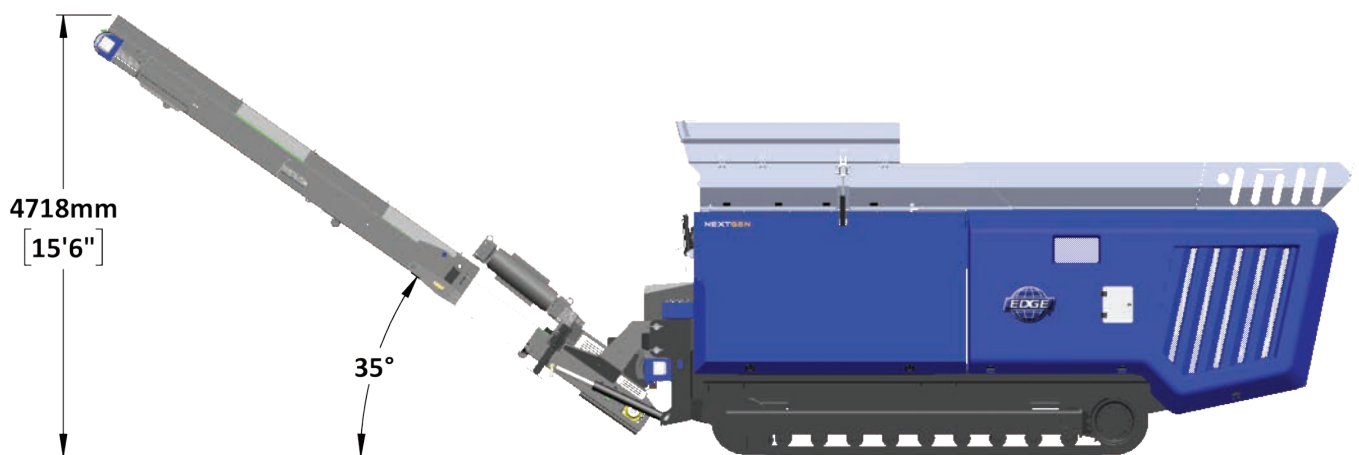
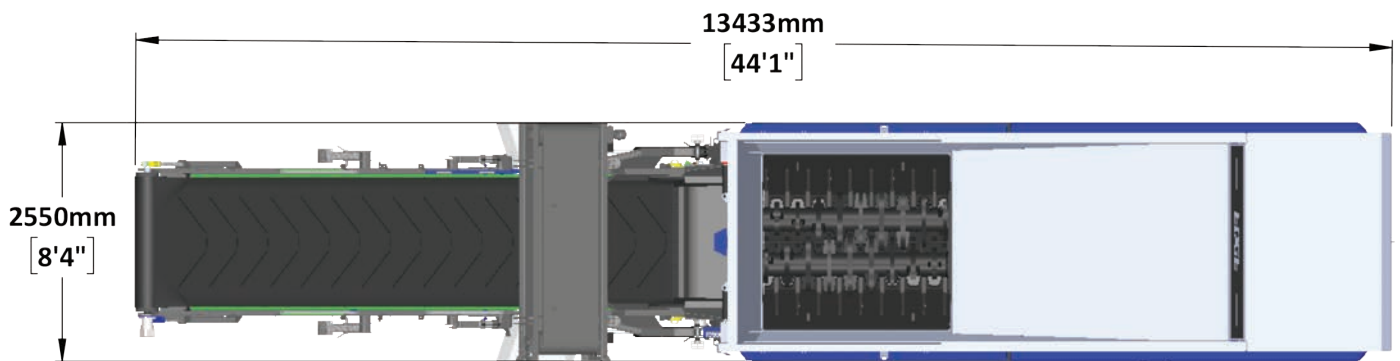

AVAILABLE OPTIONS

CHAMBER CONFIGURATIONS



Universal Primary Shredder Chamber - Rapid volume reduction solution



Bulky Waste Chamber - Primary shredding solution for abrasive waste



Fine Shredding Chamber - Deployed as either a primary or secondary shredder

CHASSIS FORMATS



Tracked Mounted - Fully tracked for on-site manoeuvrability



Wheel Mounted - Ideal for operators with multiple site or rental contractors



Hooklift Mounted - making relocation from site to site as simple as possible

POWER-SOURCE CONFIGURATIONS



Tier 4 Final / Stage 5 - CATERPILLAR C9.3B 310Kw (420HP)



Tier 3 LRC - CATERPILLAR C9.3 310Kw (420HP)

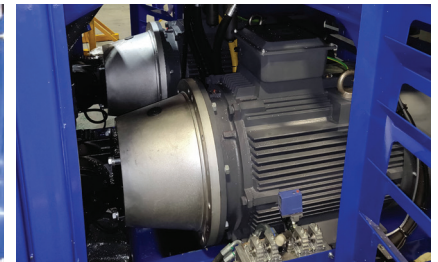

Electric / Hydraulic - available with wheeled, hooklift & static mounted units

ADDITIONAL OPTIONS



Overband Magnet - fitted to discharge conveyor to extract ferrous metal



Rubber Track Pads



Central Auto-lube System



Dust Suppression System and Water Pump



Hydraulic Raise / Lower Hopper Extensions

Additional customisation is available upon request. Speak to your nearest EDGE distributor for details.

PRODUCT AND TECHNICAL SUPPORT

TRIED, TESTED & TRUSTED THROUGHOUT THE GLOBE

With our ethos of “**Innovation at Work**” EDGE not only persist in pushing the boundaries of design and manufacturing to produce hard working, quality machinery, we also bring that same ethos to our aftersales service in order to bring real benefits to customers right across the world.

At EDGE we like to see the sales transaction as the start of a long-term partnership. Our goal is to offer the best customer support in the market for the lifetime of the unit. EDGE has reinvested and expanded our aftersales department in order to streamline and provide the customer support we believe our customers deserve.

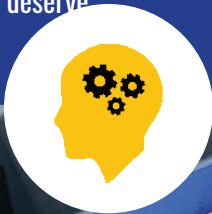

**TECHNICAL
ASSISTANCE**



**PARTS
AVAILABILITY**



DELIVERY



WARRANTY



NEXTGEN

VERTICAL SHREDDING LINE



**CONTACT US
TODAY.**

30 Farlough Road, Dungannon, Co.Tyrone, BT71 4DT, Northern Ireland

 +44(0)2887 740525  info@edgeinnovate.com  edgeinnovate.com